

C-LAS Series

▶ C-LAS-LT-35-...

Laser displacement sensor with background suppression

- Visible red laser light 670 nm, class 2 laser product
- High dynamic range, high switching accuracy
- Automatic laser power correction
- Working range typ. 25 mm ... 50 mm
- Potentiometer for adjustment of scanning distance
- Two switching outputs (PNP no/nc or NPN no/nc)
- High switching frequency (typ. 1 kHz)
- Scratch-resistant optics made of glass
- Short circuit protection, reversed polarity protection
- 4-pole M8-connector made of metal
- Yellow LED for switching state indication (in M8 connector)
- Sturdy plastic housing
- Mounting unit available

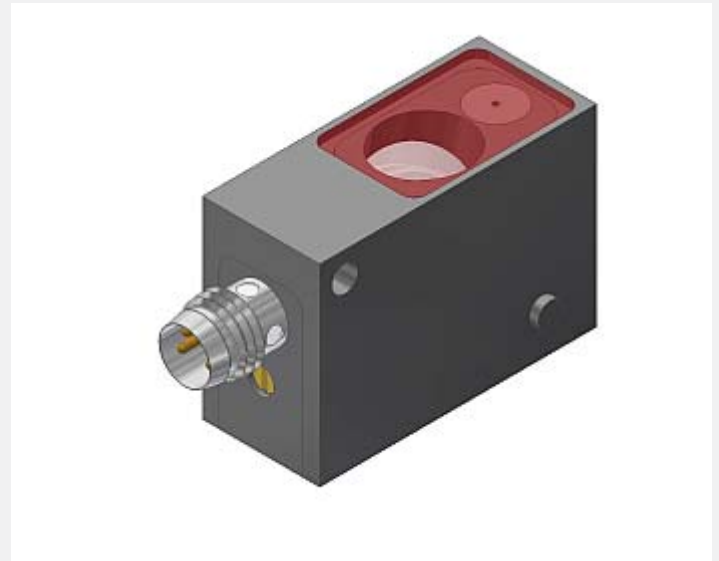

Design

Product name:

C-LAS-LT-35-(switching output)

Accessories: (cf. page 6)

MOUNT-23/34 Mounting device

Switching output selectable:

P = 1x PNP dark-switching (PNP n.o.),
1x PNP bright-switching (PNP n.c.)

N = 1x NPN dark-switching (NPN n.o.),
1x NPN bright-switching (NPN n.c.)

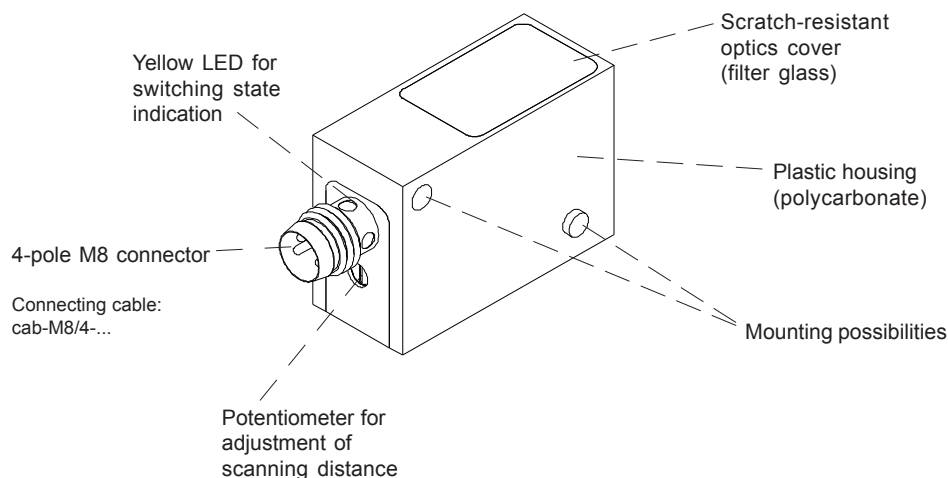



Technical Data

Model	C-LAS-LT-35-P	C-LAS-LT-35-N
Light source	Semiconductor laser: 670 nm, 1 mW max. opt. output, class 2 laser product acc. to DIN EN 60825-1. The use of these laser transmitters therefore requires no additional protective measures.	
Reference distance	typ. 35 mm	
Working range (scanning distance)	typ. 25 mm ... 50 mm	
Laser beam focus	at a distance of typ. 50 mm	
Size of laser spot	in the focus (at 50 mm distance): typ. < 0.2 mm at laser light exit at sensor: typ. < 2 mm	
Min. detectable object (at a distance of 50 mm)	typ. 50 µm	
Optical filter	Red light filter RG645	
Voltage supply	+24VDC (± 10%), reversed-polarity protection, overcurrent protection	
AC operation	typ. 100 kHz	
Ambient light	Up to 5000 Lux	
Enclosure rating	IP67	
Current consumption	Approx. 50 mA	
EMC test acc. to	DIN EN 60947-5-2 	
Connector type	Connection to PLC: 4-pole M8 connector	
Connecting cable	cab-M8/4-...	
Working temperature range	-20°C ... +55°C	
Storage temperature range	-20°C ... +85°C	
Housing material	Polycarbonate, black	
Housing dimensions	LxWxH approx. 33 mm x 16 mm x 23 mm (without connector)	
Rise time / fall time	<= 1 ms	
Max. switching current	100 mA, short-circuit protection	
Switching frequency	typ. 1 kHz	
Outputs	1x pnp dark-switching (pnp normally open) 1x pnp bright-switching (pnp normally closed)	1x npn dark-switching (nnp normally closed) 1x npn bright-switching (pnp normally open)
Switching state indication	By means of a yellow LED (integrated in the M8 connector)	
Laser power correction	Due to integrated laser power correction, the sensor is largely independent of brightness of measuring object (for instance KODAK white and KODAK black)	
Adjustment of scanning distance	by means of a potentiometer (can be rotated 270°)	



Laser Warning

The transmitters of the laser sensors of C-LAS Series comply with laser class 2 according to EN 60825-1. The use of these transmitter requires no additional protective measures.

The transmitters of C-LAS Series are supplied with a laser warning label.

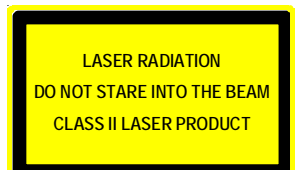

Technical Data

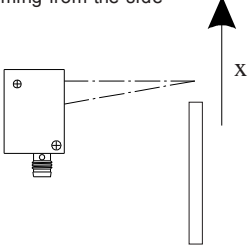
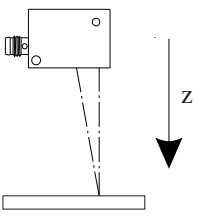
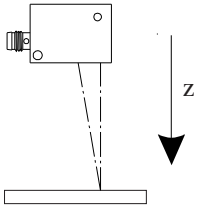
Model	C-LAS-LT-35
<p>Repeatability for targets coming from the side</p> 	<p>to the target (black mat): typ. $\pm 30 \mu\text{m}$ (at distance 25 mm ... 45 mm) to the target (white mat): typ. $\pm 20 \mu\text{m}$ (at distance 25 m ... 45 mm) from the target (black mat): typ. $\pm 30 \mu\text{m}$ (at distance 25 mm ... 45 mm) from the target (white mat): typ. $\pm 20 \mu\text{m}$ (at distance 25 mm ... 45 mm)</p> <p>Switching hysteresis (to the target/from the target): typ. $< 100 \mu\text{m}$</p>
<p>Offset caused due to change of the target from white mat to black mat (target coming from the side)</p>	<p>typ. $< 250 \mu\text{m}$ (at distance 25 mm ... 45 mm)</p>
<p>Repeatability for targets moved directly to the sensor respectively from the sensor</p> 	<p>to the target (black mat): typ. $\pm 100 \mu\text{m}$ (at distance 25 mm ... 45 mm) to the target (white mat): typ. $\pm 50 \mu\text{m}$ (at distance 25 mm ... 45 mm) from the target (black mat): typ. $\pm 100 \mu\text{m}$ (at distance 25 mm ... 45 mm) from the target (white mat): typ. $\pm 50 \mu\text{m}$ (at distance 25 mm ... 45 mm)</p> <p>Switching hysteresis (to the target/from the target): typ. 1 mm (at distance 25 mm ... 35 mm) typ. 2 mm (at distance 35 mm ... 45 mm) typ. 4 mm (at distance 50 mm)</p>
<p>Offset caused by a target change from white mat to black mat (target moved directly to the sensor)</p> 	<p>typ. $< \pm 150 \mu\text{m}$ (at distance 25 mm ... 45 mm)</p>

Dimensions

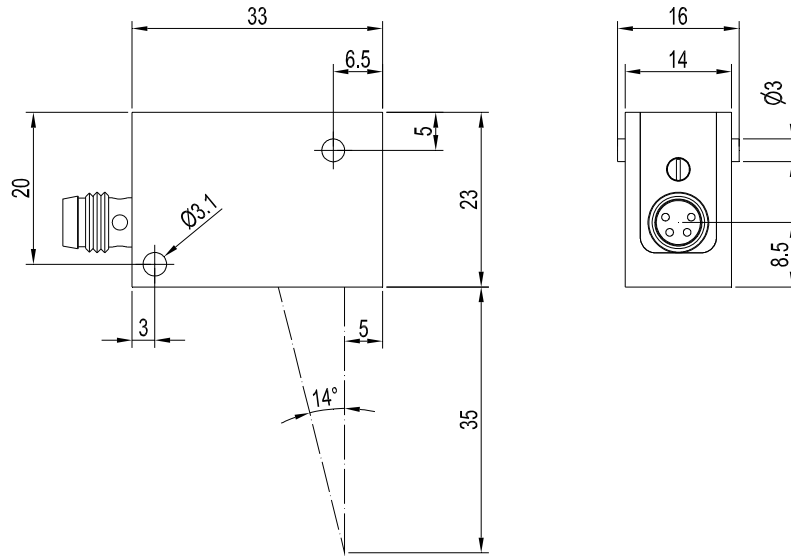

(All dimensions in mm)

Adjustment

Potentiometer for adjustment of target distance:

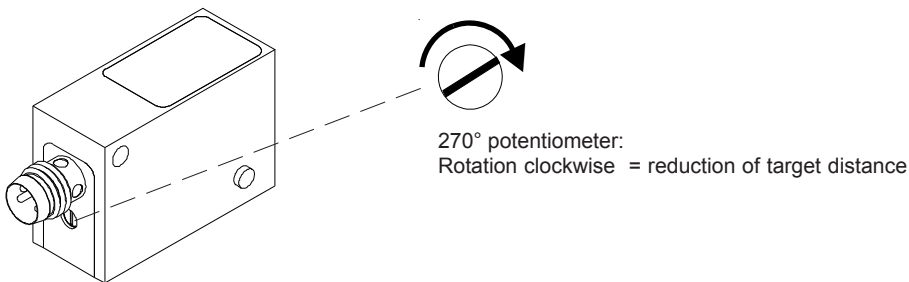



Connector Assignment

Connection to PLC:

**Type C-LAS-LT-35-P (switching output P):
4-pole M8 connector**

Pin No.:	Color:	Assignment:
1	brown	+24VDC (± 10%)
2	white	OUTPUT PNP dark-switching (PNP n.o.)
3	blue	GND (0V)
4	black	OUTPUT PNP bright-switching (PNP n.c.)

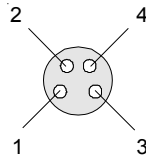

**Type C-LAS-LT-35-N (switching output N):
4-pole M8 connector**

Pin No.:	Color:	Assignment:
1	brown	+24VDC (± 10%)
2	white	OUTPUT NPN dark-switching (NPN n.o.)
3	blue	GND (0V)
4	black	OUTPUT NPN bright-switching (NPN n.c.)

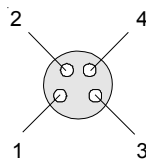

Connecting cable for each type:
 cab-M8/4-g-(length) or
 cab-M8/4-w-(length) (angle type 90°)
 (standard length 2m)



Connecting Cables

Available connecting cables:

cab-M8/4-g-2	Length: 2 m	Sheath: PUR
cab-M8/4-g-5	Length: 5 m	Sheath: PUR
cab-M8/4-w-2	Length: 2 m	Sheath: PUR - angle type 90°
cab-M8/4-w-5	Length: 5 m	Sheath: PUR - angle type 90°

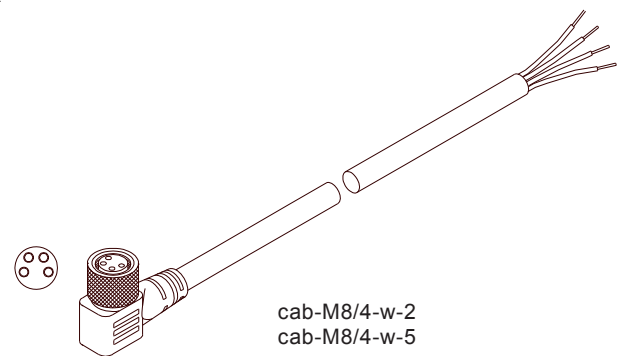
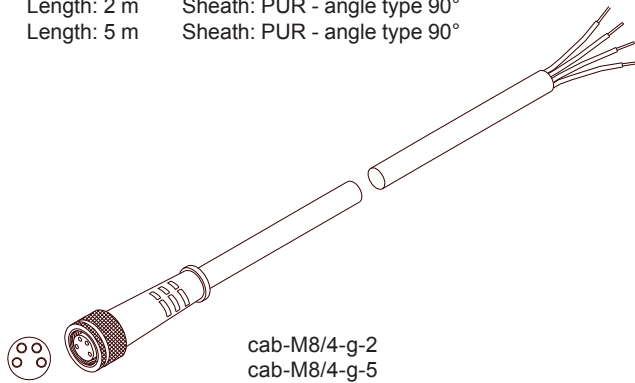

Mounting

Mounting device: MOUNT-23/34
(please order separately)

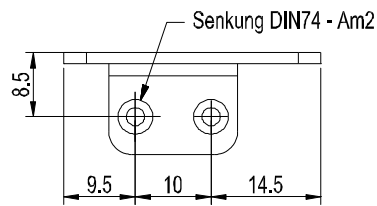
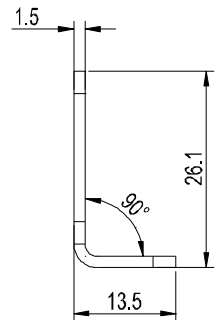
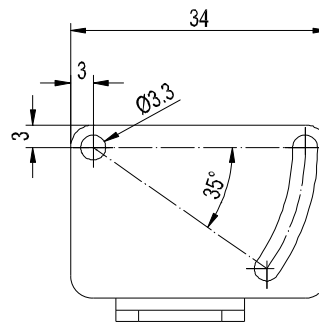
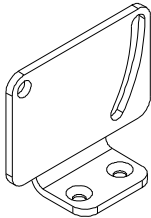

(All dimensions in mm)

Product Line

Overview of Compact Laser Sensors:

C-LAS-LT-35-...
C-LAS-LT-65-...
Laser displacement sensor
with background suppression

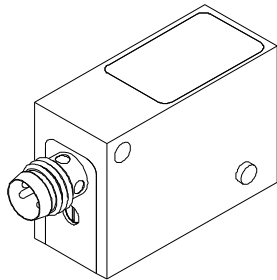

C-LAS-LT-35-ANA
C-LAS-LT-65-ANA
Laser displacement sensor
with analog output

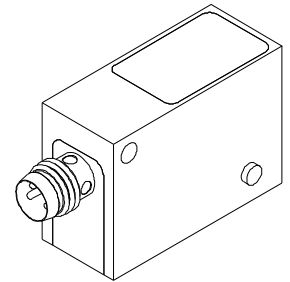

C-LAS-14-T/-R (split version: transmitter and receiver)
Laser oneway light barrier

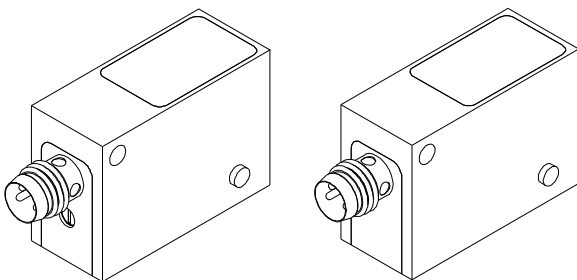

C-LAS-LR-OP2-...
Laser reflection light barrier
with polarisation filter
(object serves as a reflector)

C-LAS-LR-RP2-...
Laser reflection light barrier
with polarisation filter
(reflector or reflector foil)

