

# FLB Series

## ▶ FLB-MSHC-1020

**Infrared multiple light barrier  
for determination of punching tape position**

At punching belt feeding systems the height of the punching tape is monitored.

- Max. transmitter/receiver distance typ. 200 mm
- Monitoring area typ. 950 mm
- 24 light barriers (screen 40 mm)
- Reaction period < 1 ms
- 2 analog outputs (0V ... +10V or 4mA ...20mA)
- Controller integrated in the receiver
- Sturdy aluminum housing, anodized in black
- Integrated impact protection



### Design

**Product name:**

**FLB-MSHC-1020-T** (Transmitter)

**FLB-MSHC-1020-R** (Receiver)

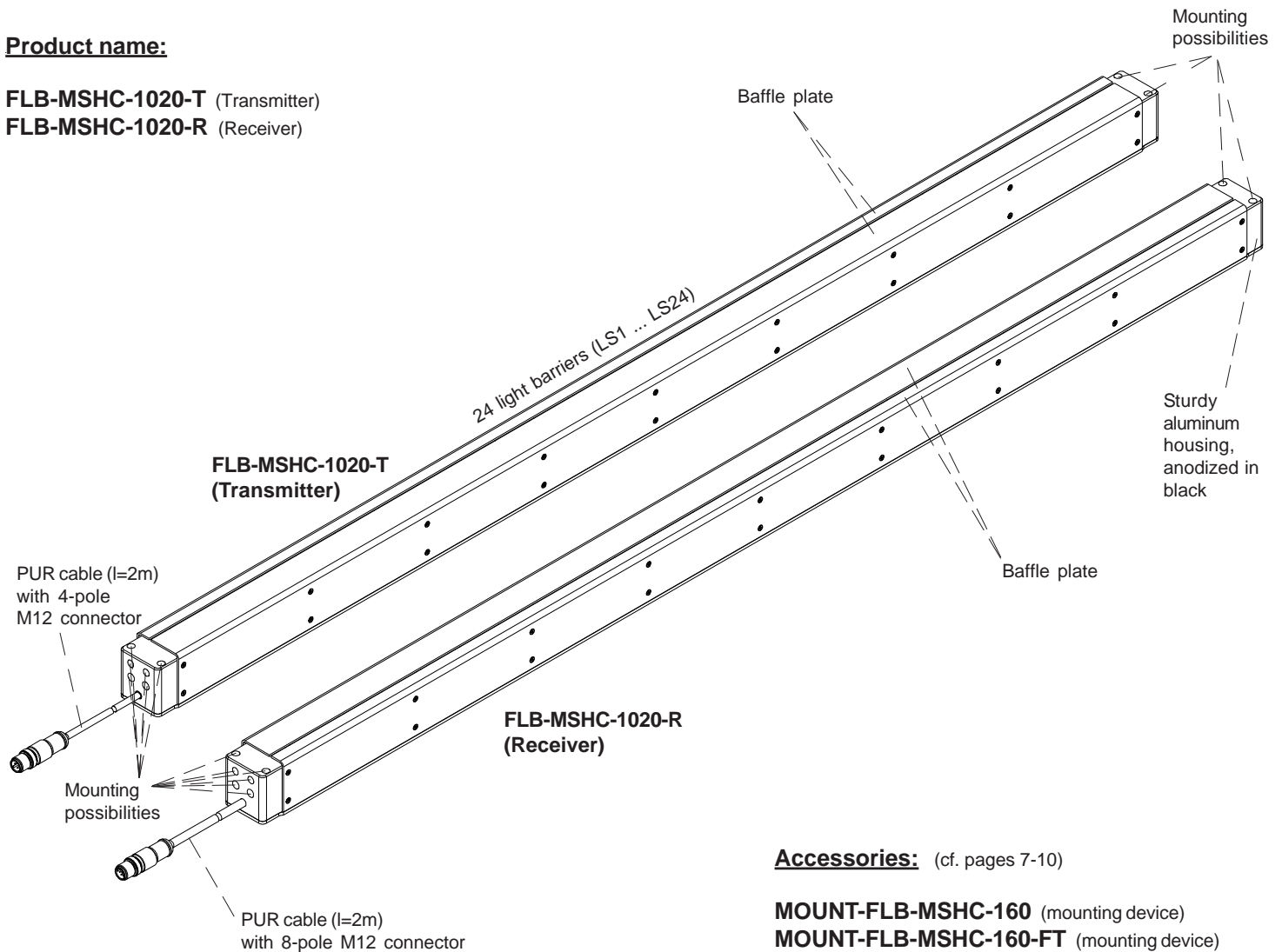

**Accessories:** (cf. pages 7-10)

**MOUNT-FLB-MSHC-160** (mounting device)

**MOUNT-FLB-MSHC-160-FT** (mounting device)  
(please order separately)



**Technical Data**

Model	FLB-MSHC-1020-T (Transmitter) FLB-MSHC-1020-R (Receiver)
Max. distance transmitter/receiver	typ. 200 mm
Monitoring range	typ. 950 mm
Transmitter	24 IR-LEDs (905 nm)
Receiver	24 photo transistors
Voltage supply	+24V ± 10%, short-circuit proof
Resolution	approx. 0.4 V respectively 0.7 mA (approx. 40 mm)
Optical filter	IR filter RG715
Digital ALARM output	switches when the top light barrier (LS24) or the bottom light barrier (LS1) is interrupted
Analog outputs (2x)	ANALOG voltage 0V ... +10V und ANALOG current 4mA ... 20mA
Band width analog signals	1 kHz
Current consumption	< 350 mA
Aperture size of receiver	24x circular aperture: Ø 1 mm
Enclosure rating	IP67
Operating temperature range	-20°C ... +50°C
Storage temperature range	-20°C ... +85°C
Housing material	Aluminium, anodized in black
Dimensions	FLB-MSHC-1020-T (transmitter) and FLB-MSHC-1020-R (receiver): each LxWxH approx. 1032 mm x 46.5 mm x 43 mm
Connectors	FLB-MSHC-600-T (transmitter): PUR cable (length 2 m, shielded) with 4-pole M12-connector FLB-MSHC-600-R (receiver): PUR cable (length 2 m, shielded) with 8-pole M12-connector
Connecting cable (optional)	for mounting device MOUNT-FLB-MSHC-160 or MOUNT-FLB-MSHC-160-FT (optional): cab-M12/8-g-...-shd (standard length 2 m, shielded)
EMC test acc. to	DIN EN 60947-5-2
Scan frequency	typ. 50 kHz

**Dimensions**

**FLB-MSHC-1020-T**  
(Transmitter)

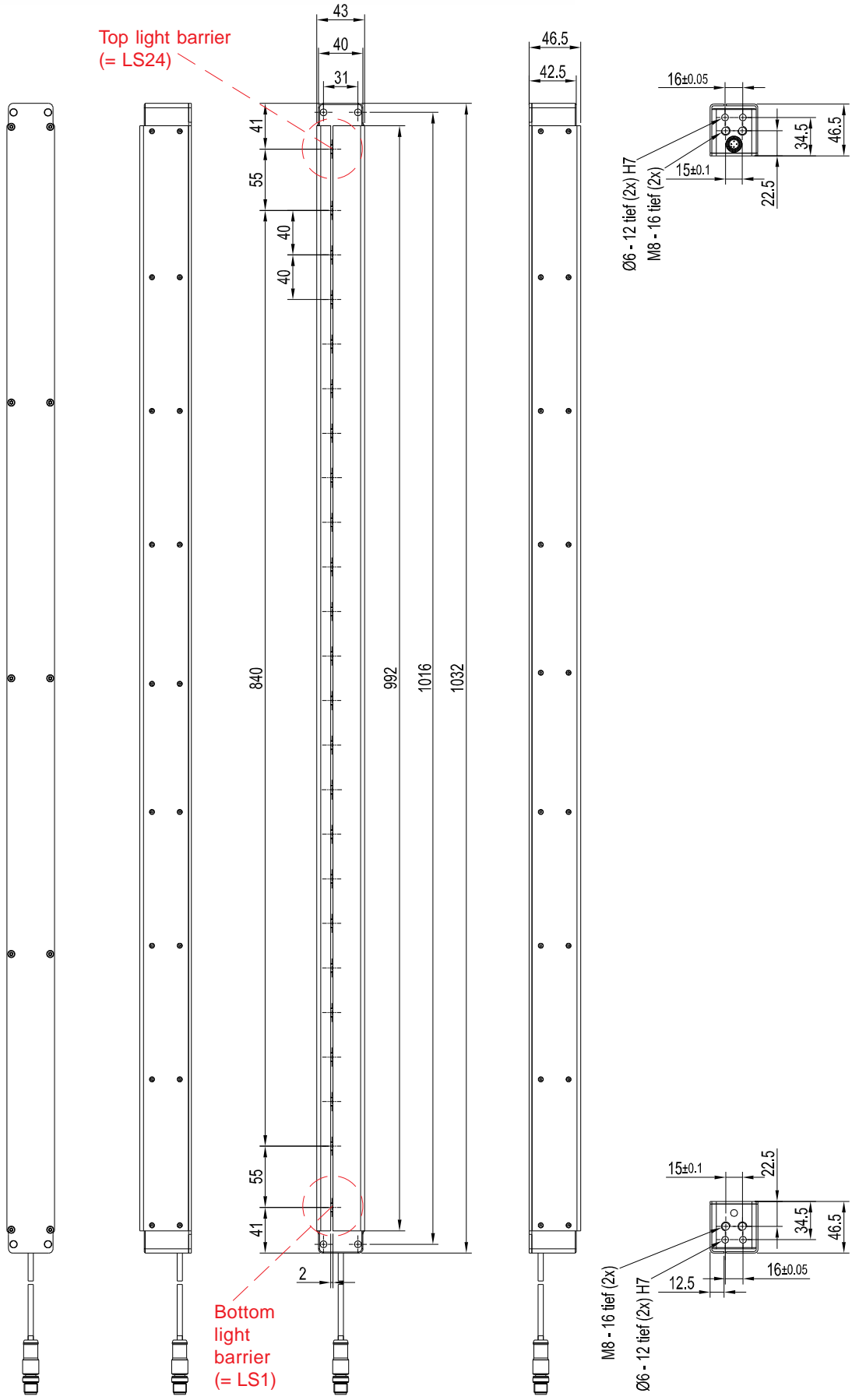

All dimensions in mm

**Dimensions**

**FLB-MSHC-1020-R**  
(Receiver)

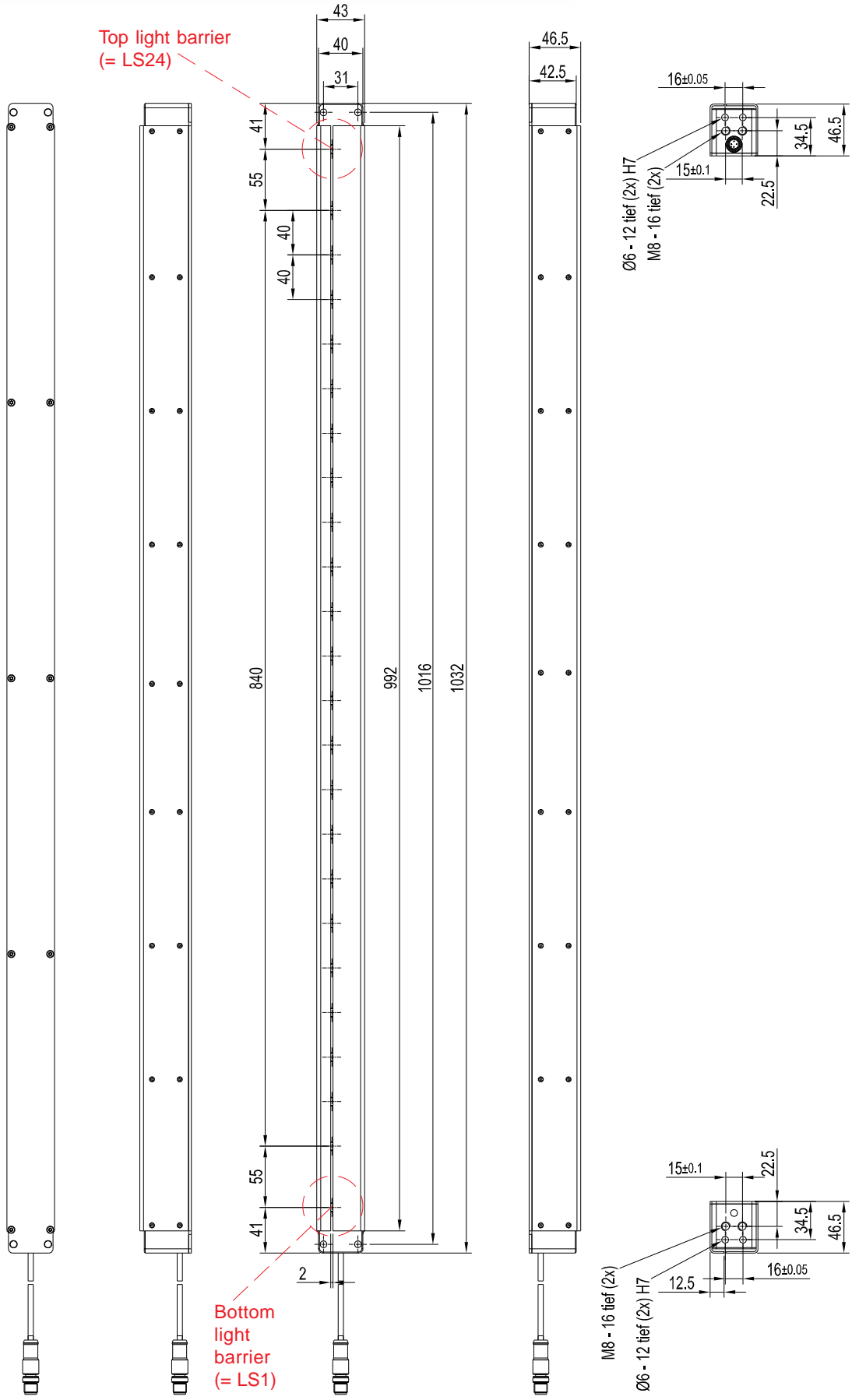

All dimensions in mm



**Connector Assignment**

**FLB-MSHC-1020-R (Receiver)**

**Assignment 8-pole M12 connector**

Pin:	Assignment:
1	GND (0V)
2	+24VDC ( $\pm 10\%$ )
3	ANALOG (Voltage 0V ... +10V)
4	ANALOG (Current 4mA .... 20mA)
5	ALARM
6	not connected
7	not connected
8	not connected

**FLB-MSHC-1020-T (Transmitter):**

**Assignment 4-pole M12 connector**

Pin:	Assignment:
1	+24VDC ( $\pm 10\%$ )
2	not connected
3	GND (0V)
4	not connected

**Optional:**

**Connector assignment when using the mounting device  
MOUNT-FLB-MSHC-160 or MOUNT-FLB-MSHC-160-FT**

**Assignment 8-pole M12 connector**

(at the MOUNT-FLB-MSHC-... connector box, see illustration):

Pin:	(color:)	Assignment:
1	(white)	GND (0V)
2	(brown)	+24VDC ( $\pm 10\%$ )
3	(green)	ANALOG (Voltage 0V ... +10V)
4	(yellow)	ANALOG (Current 4mA .... 20mA)
5	(grey)	ALARM
6	(pink)	not connected
7	(blue)	not connected
8	(red)	not connected

Connecting cable:  
cab-M12/8-g-(length)-shd  
(standard length 2m)

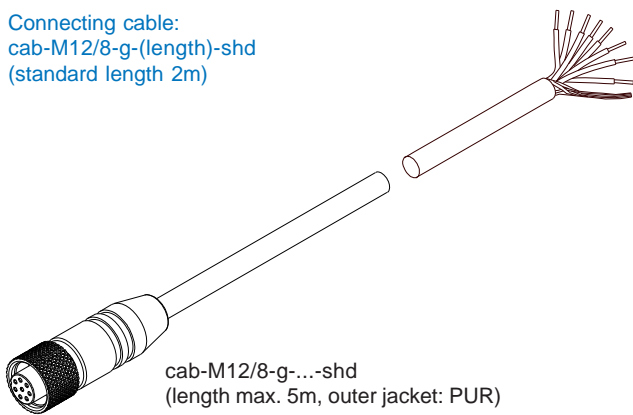

cab-M12/8-g-...-shd  
(length max. 5m, outer jacket: PUR)

8-pole M12 connector.  
Connecting cable:  
cab-M12/8-g-...-shd

MOUNT-FLB-MSHC-160  
connector box

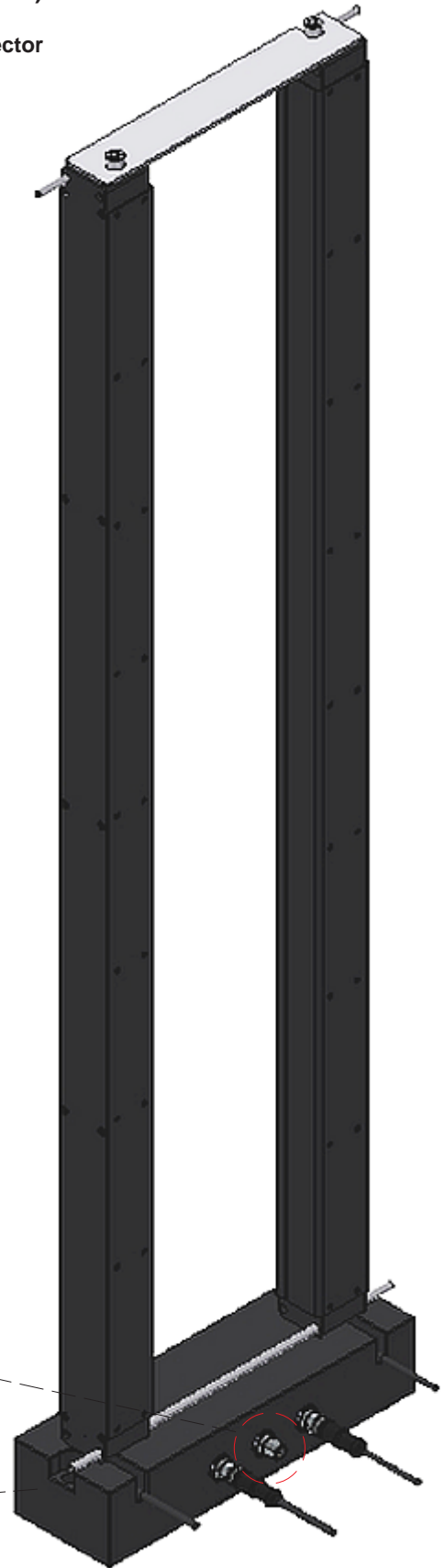

**Measuring Principle****Design**

The sensor system consists of a transmitter unit FLB-MSHC-1020-T and a receiver unit FLB-MSHC-1020-R. Transmitter and receiver unit are supplied with +24 V  $\pm$  10%.

The complete electronic evaluation module is integrated in the receiver unit FLB-MSHC-1020-R, which provides two analog signals (0 ... +10 V and 4 mA ... 20 mA) at the 8-pole M12 connector.

The analog values are divided into 24 steps: With each step the analog value increases by approx. 0.4 V respectively 0.7 mA. After initialisation, the analog value is 0 V respectively 4 mA. The bandwidth of the analog outputs is 1 kHz.

In addition, a digital ALARM output is available, which switches when the top light barrier (LS24) or the bottom light barrier (LS1) is interrupted.

**Measuring principle**

24 light barriers that are uniformly distributed over 600 mm are used, which results in a grid of 40 mm.

IR-LEDs with low divergence are used as transmitter diodes, which guarantees that there is no mutual influencing of the light barriers.

24 phototransistors are used as receivers, the receiving area is limited to approx. 1 mm. The phototransistors are set back in order to additionally increase the aperture effect.

The individual light barriers are not modulated in order to achieve as high a measuring frequency as possible. Outside light suppression rather is effected by IR filtering (glass cover with IR filter and additional IR filter at the phototransistors).

The individual phototransistors are read by the controller that is integrated in the receiver with a frequency of approx. 50 kHz. When the individual light barriers are covered, both analog signals are generated in the controller. The values of the analog signals are coupled to the respective interrupted light barrier.

When the lowest light barrier LS1 (see drawings page 3 and 4) is interrupted (also in case of short-time interruption), the analog value increases to 0.4 V respectively 4.7 mA. When the second light barrier LS2 is interrupted, the analog value increases to 0.8 V respectively to 5.4 mA, etc. The value is maintained at the analog outputs until one of the 24 light barriers is interrupted again.

**Accessories**

**Mounting device**  
**MOUNT-FLB-MSHC-160**  
 (without base plate and feet)

**160 = Distance (mm) between transmitter and receiver**

**MOUNT-FLB-MSHC-160**  
 consists of:

- 1x connector box
- 1x transport safety
- 2x alignment aid

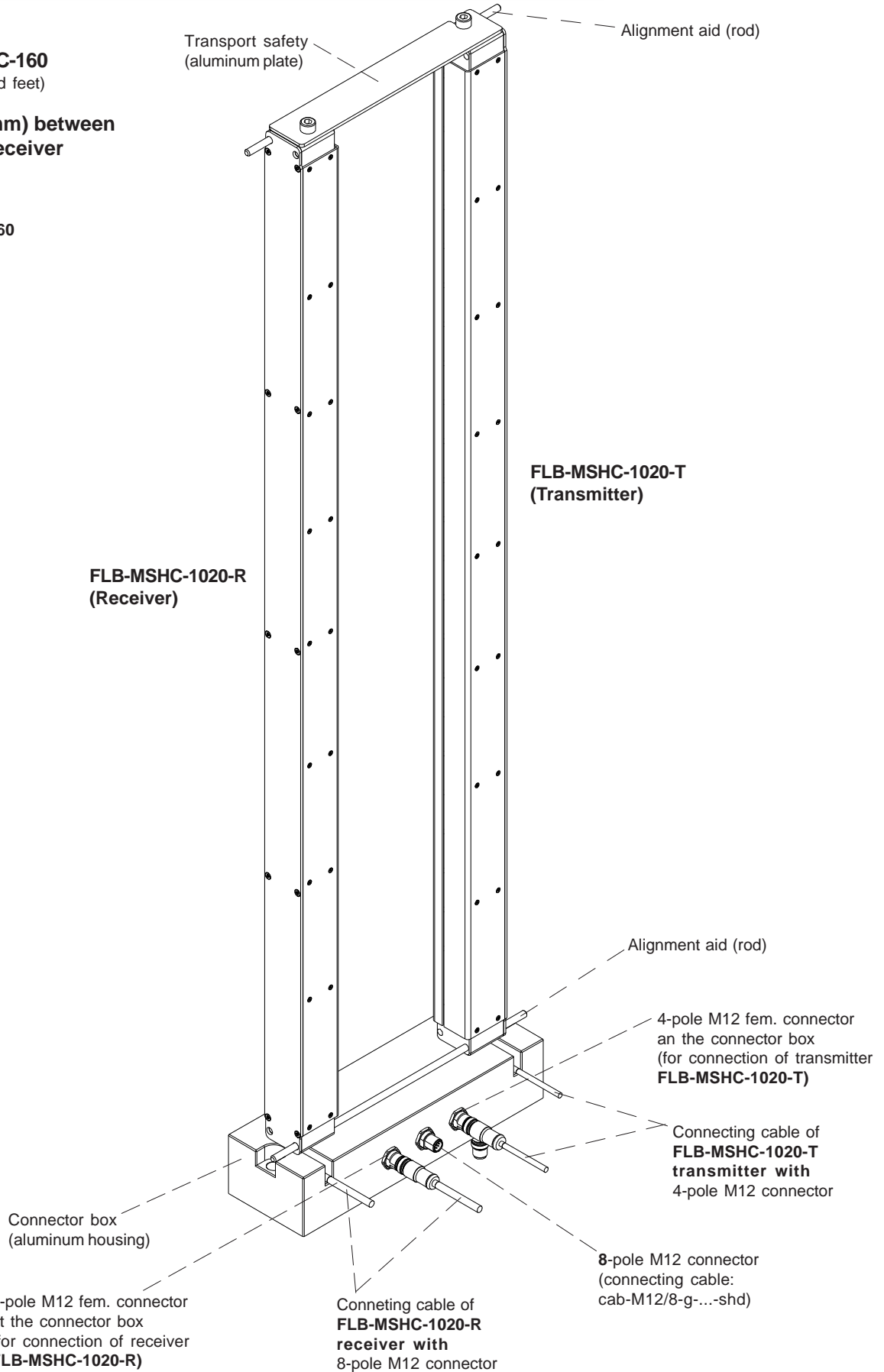



Accessories

**Dimensions:**

**Mounting device**  
**MOUNT-FLB-MSHC-160**  
(without base plate and feet)

Picture with FLB-MSHC-1020-T/-R

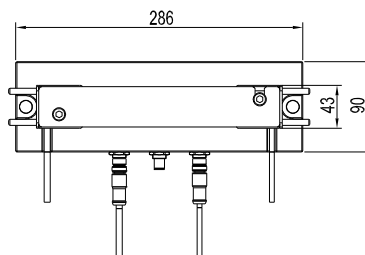
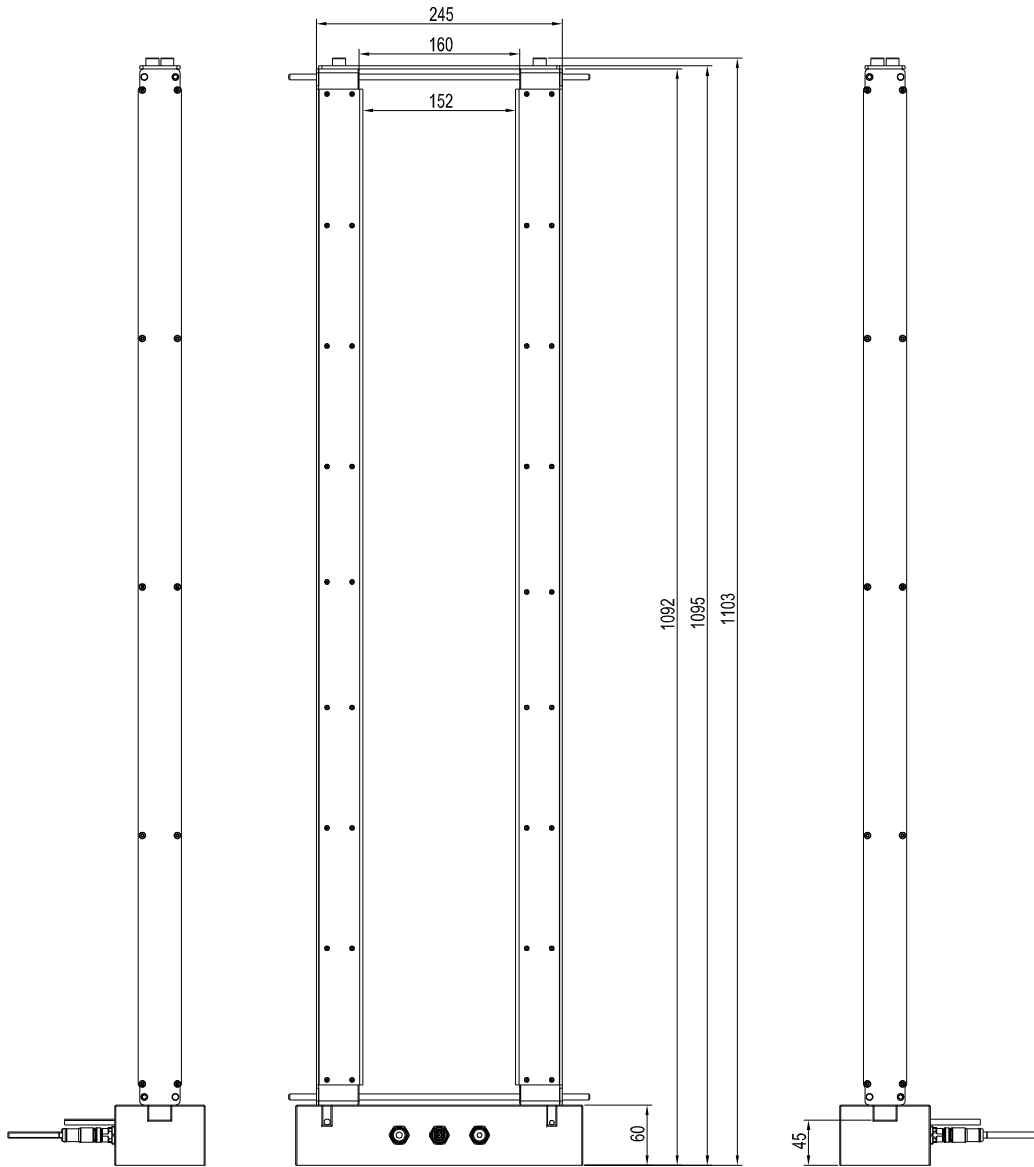
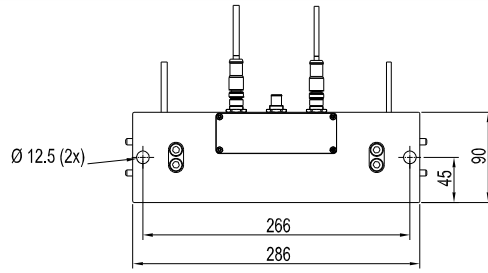

All dimensions in mm





**Accessories**

**Mounting device**  
**MOUNT-FLB-MSHC-160-FT**  
 (with base plate and feet)

**160 = Distance (mm) between transmitter and receiver**

**MOUNT-FLB-MSHC-160-FT consists of:**

- 1x connector box
- 1x transport safety
- 2x alignment aid
- 1x base plate
- 4x feet

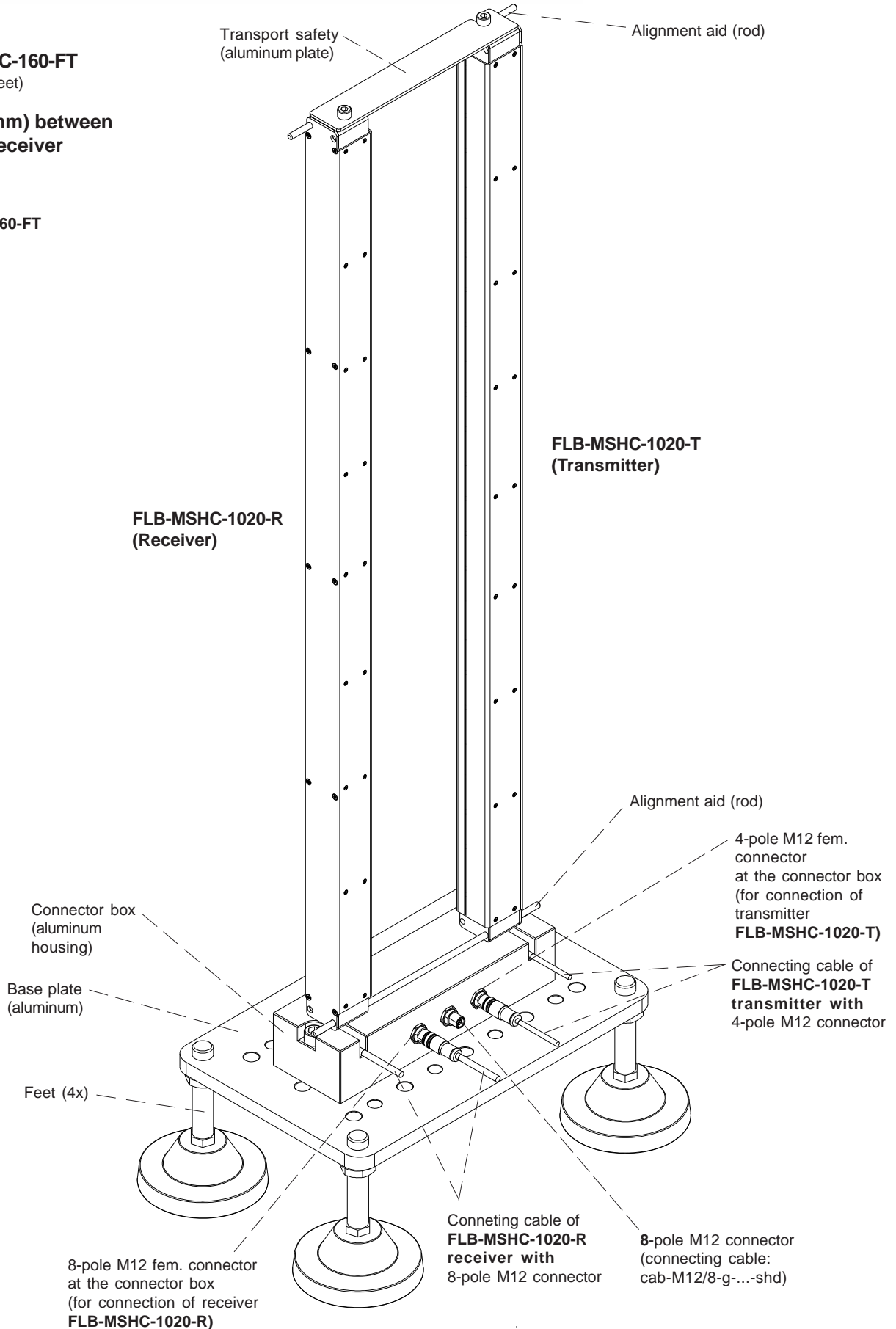



**Accessories**

**Dimensions:**

**Mounting device**  
**MOUNT-FLB-MSHC-160-FT**  
 (with base plate and feet)

Picture with FLB-MSHC-1020-T/R

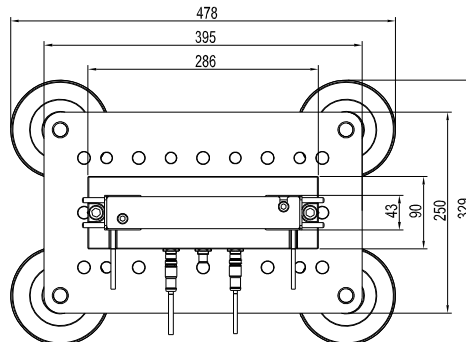
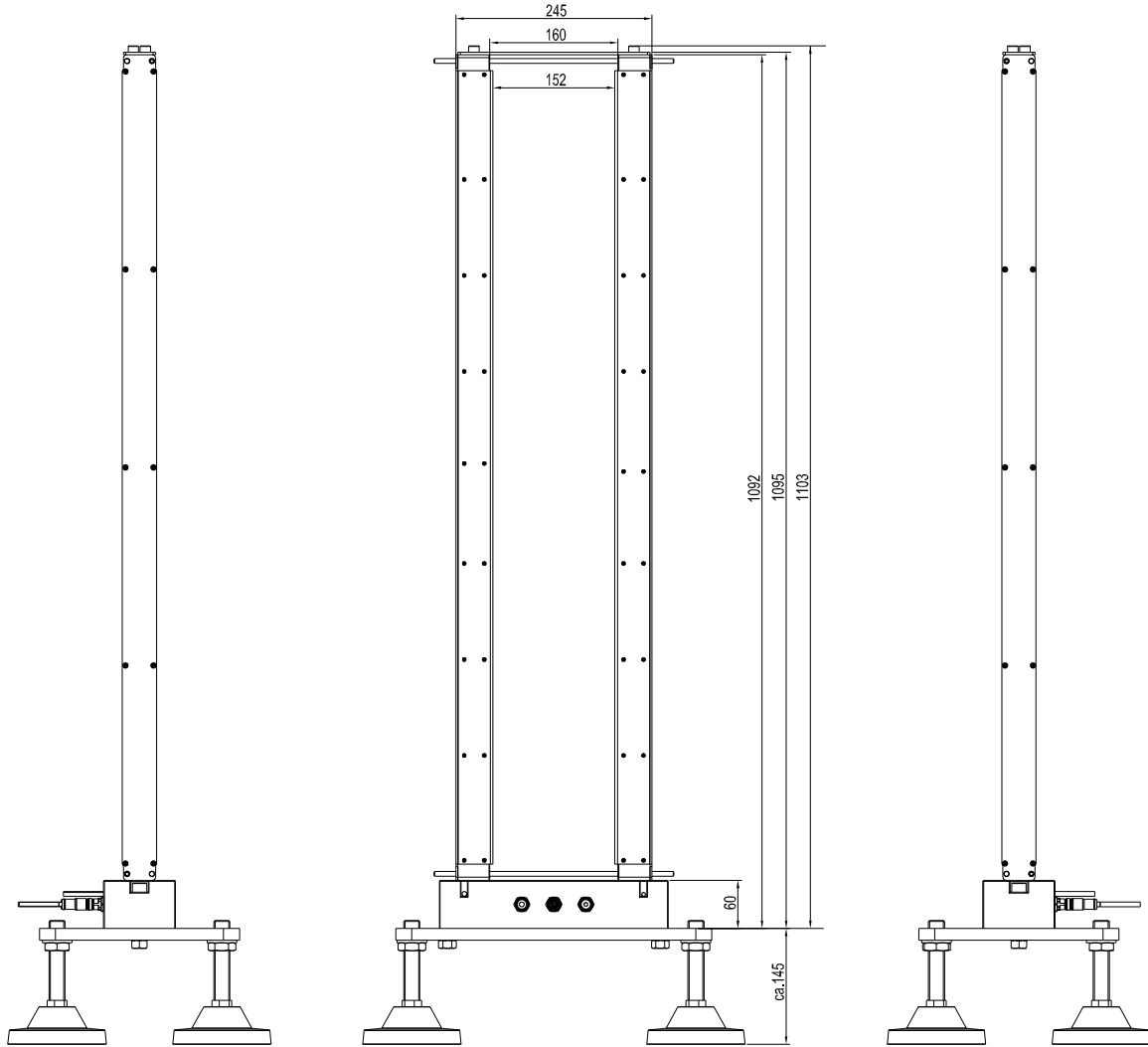
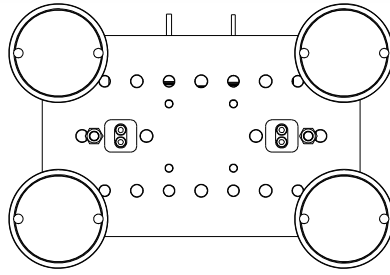

All dimensions in mm